



1640 x 800 x 100 mm



39 kg



Steel / HDG



EN 12811

Description

The modular Vivatec Stairway 70/3 is the safe replacement of a ladder on construction sites. It is easy to combine, produced in accordance with the respective norms and can be crane-operated thanks to pre-assembled crane hooks. Thanks to the intelligent design the assembly effort is very low.

Each individual part of the stairway can conveniently be replaced in the event of damage.

To simplify transportation and storage the stairways can be folded flat. Even more complicated platform constructions can be carried out with the help of Vivatec stairways 70/3.

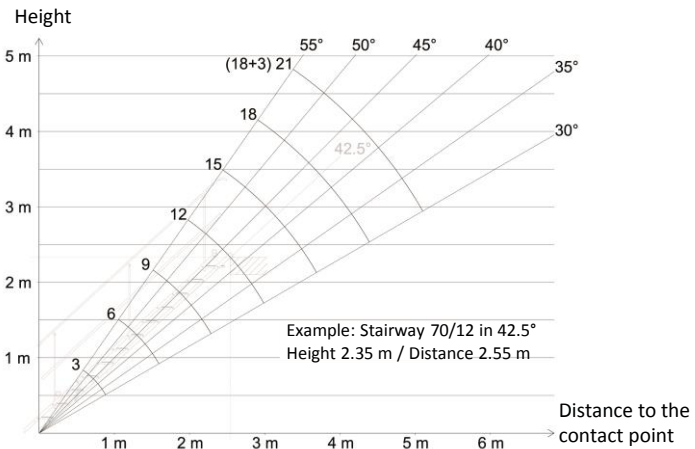
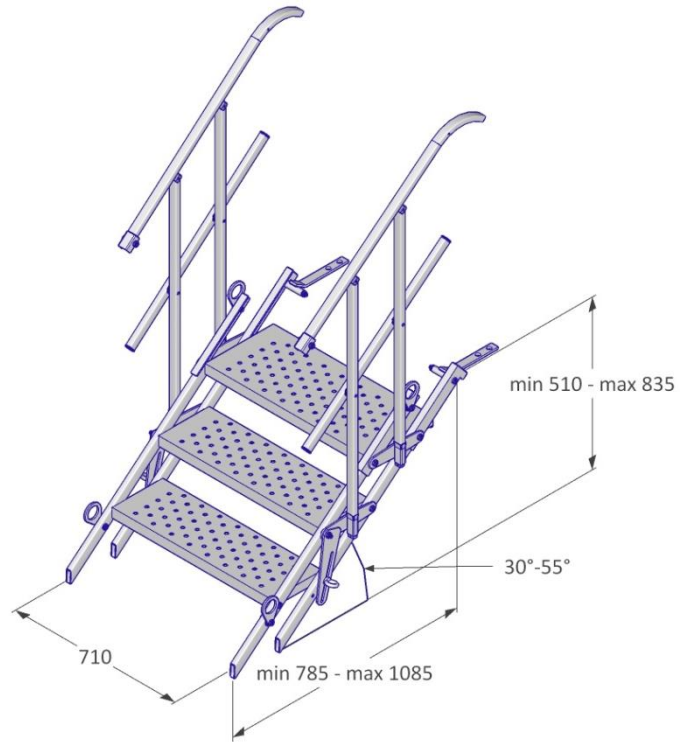

10 pcs / Euro Pallet



1640 x 800 x 1200 mm



410 kg

Means of Fixation

Tensile load of the screws min. 10 kN
 → Hilti HUS3-H8-75mm or the like / better, assembly torque limit min. 60 Nm

General Safety

Health and Safety Regulation should be followed at all times. For more information → viva-tec.com/safety