



224 x 60 x 60 mm



0,60 kg



Stahl / feuerverzinkt

Beschreibung

Der VT Adapter 25 fixiert jeden standardmäßig verfügbaren Vivatec Pfosten in der Einbetonierhülse – 25 mm Rundstahl zu 35 mm Vierkant.

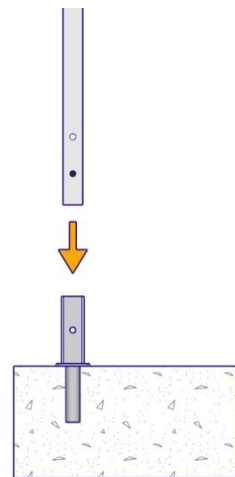
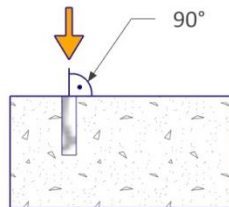
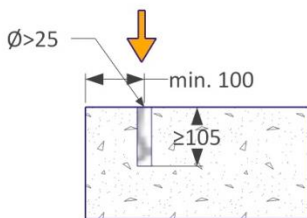
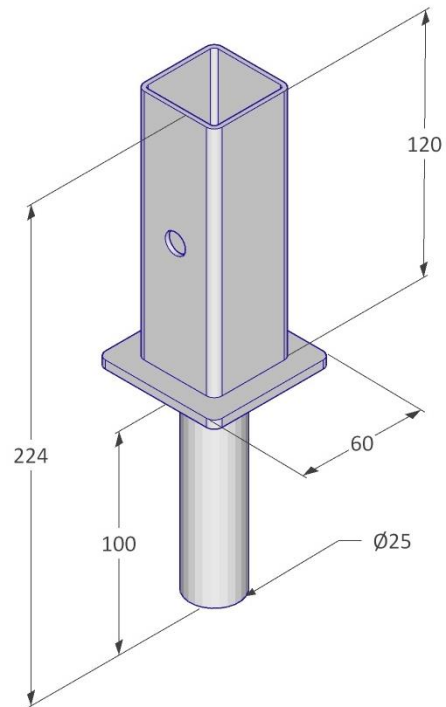

mm



500 Stk. / Eurobox



1240 x 835 x 970 mm



370 kg

Sicherheitshinweis

Geltende Gesundheits- und Sicherheitsvorschriften sind einzuhalten, für mehr Info → viva-tec.com/sicherheit